

Tech 80% Gas Furnaces

G1N80

Features

HEAT EXCHANGER DESIGN

- Efficient aluminized steel tapered S-curve design
- Crimped no weld construction for longer life

BURNERS

- Aluminized steel inshot burners for smooth ignition

CABINET CONSTRUCTION

- Compact 40" height
- Insulated to increase efficiency and reduce sound levels
- Unitized construction for cabinet integrity
- Baked on prepainted steel cabinet finish

AIR DELIVERY SYSTEM

- Multi-speed for wide airflow range
- PSC permanently lubricated motor for low maintenance and optimum efficiency
- Easily removable slide-out blower design
- Dynamically balanced blower wheel with resilient motor mounts for smooth and quiet operation

CONTROLS

- Integrated ignition and fan control board
- Board features self diagnostics as well as saving last five (5) fault codes in nonvolatile memory for ease of service
- Provides reverse polarity protection
- Hot surface ignition using steel shrouded, high density mini-ignitor
- Control circuit is fuse protected
- Control board features adjustable fan off time in the heating mode and a 60 second fan off time delay in the cooling mode
- Control board provides terminals for electronic air cleaner, humidifier, furnace twinning, and continuous low speed fan operations

VENTING

- Permanently lubricated draft motor with stainless steel shaft and air cooled for long life

G1N80BT = Upflow / Horizontal

G1N80BU = Upflow (shown)

G1N80BR = Counterflow / Horizontal



INSTALLATION FEATURES

- Left or right gas and electric entry
- "L" models comply with California's South Coast Air Quality Management District Low NOx requirements
- Filter rack and permanent cleanable filters provided on dedicated upflow models

WARRANTY

- 10 year limited parts warranty / lifetime heat exchanger warranty available. See limited warranty document for details.

AIREASE™

Built for life.Yours.

Model Number Guide

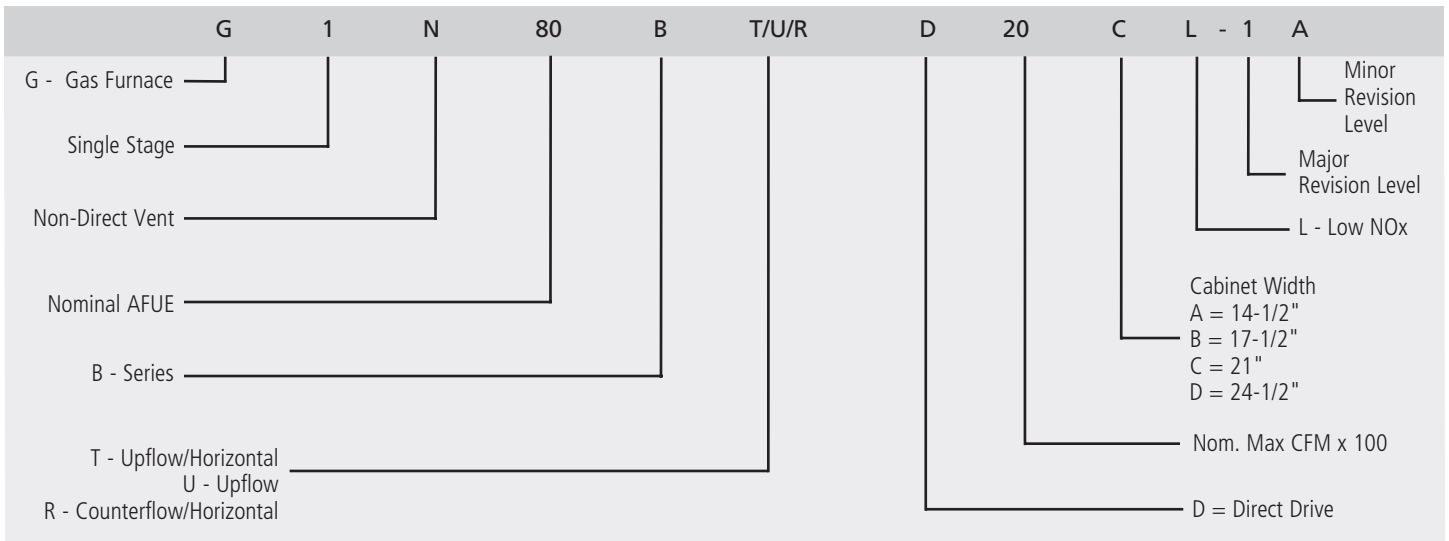

Physical and Electrical Data

Model	Input	Output	AFUE (ICS)	Nom. Cooling Capacity	Gas Inlet (in.)	Flue Size (in.)	Volts/ Hz/ Phase	Min. Time Delay Breaker or Fuse	Nominal F.L.A.	Trans. (V.A.)	Approx. Weight (lbs.)
G1N80BT050D12A	50,000	40,000	80.0%	1.5 - 3.0	1/2	4	120/60/1	15	5.8	40	125
G1N80BT075D12A	75,000	60,000	80.0%	1.5 - 3.0	1/2	4	120/60/1	15	5.6	40	130
G1N80BT075D16B	75,000	60,000	80.0%	2.5 - 4.0	1/2	4	120/60/1	15	7.7	40	140
G1N80BT100D14B	100,000	80,000	80.0%	2.0 - 3.5	1/2	5	120/60/1	15	7.3	40	160
G1N80BT100D20C	100,000	80,000	80.0%	3.0 - 5.0	1/2	5	120/60/1	15	11.2	40	170
G1N80BT100D22C	100,000	80,000	80.0%	3.0 - 5.0	1/2	5	120/60/1	15	11.3	40	180
G1N80BT125D20C	125,000	100,000	80.0%	3.0 - 5.0	1/2	5	120/60/1	15	10.5	40	180
G1N80BU050D12A	50,000	40,000	80.0%	1.5 - 3.0	1/2	4	120/60/1	15	5.8	40	125
G1N80BU075D12A	75,000	60,000	80.0%	1.5 - 3.0	1/2	4	120/60/1	15	5.6	40	130
G1N80BU075D16B	75,000	60,000	80.0%	2.5 - 4.0	1/2	4	120/60/1	15	7.7	40	140
G1N80BU100D14B	100,000	80,000	80.0%	2.0 - 3.5	1/2	5	120/60/1	15	7.3	40	160
G1N80BU100D20C	100,000	80,000	80.0%	3.0 - 5.0	1/2	5	120/60/1	15	11.2	40	170
G1N80BU125D20C	125,000	100,000	80.0%	3.0 - 5.0	1/2	5	120/60/1	15	10.5	40	180
G1N80BU150D20D	150,000	120,000	80.0%	3.0 - 5.0	1/2	5	120/60/1	15	11.0	40	200
G1N80BR050D12A	50,000	40,000	80.0%	1.5 - 3.0	1/2	4	120/60/1	15	5.4	40	130
G1N80BR075D12A	75,000	60,000	80.0%	1.5 - 3.0	1/2	4	120/60/1	15	5.6	40	140
G1N80BR075D16B	75,000	60,000	80.0%	2.5 - 4.0	1/2	4	120/60/1	15	6.8	40	155
G1N80BR100D14B	100,000	80,000	80.0%	2.0 - 3.5	1/2	5	120/60/1	15	7.1	40	160
G1N80BR100D20C	100,000	80,000	80.0%	3.0 - 5.0	1/2	5	120/60/1	15	11.2	40	175
G1N80BR125D20C	125,000	100,000	80.0%	3.0 - 5.0	1/2	5	120/60/1	15	11.4	40	185
G1N80BR150D20D	150,000	120,000	80.0%	3.0 - 5.0	1/2	5	120/60/1	15	11.3	40	195

Filter Requirement Data

Maximum Airflow (CFM) ¹	Disposable Filters			Permanent (Cleanable) Filters ²		
	Minimum Area (sq. in.) ³	Size (in.) ³	Quantity	Minimum Area (sq. in.) ³	Size (in.) ³	Quantity
1200	576	16 x 20	2	288	16 x 20	1
1400	672	20 x 20	2	336	20 x 20	1
1600	768	20 x 20	2	384	20 x 20	1
2000	960	20 x 25	2	480	20 x 25	1

1. The Maximum Airflow is the two digits following the "D" in the model number x 100; e.g. "14 x 100 = 1400" is the maximum airflow for G1N80BT100D14B.

2. Areas and dimensions shown for permanent (cleanable) filters are based on filters rated at 600 feet per minute face velocity.

3. Typical filter sizes are shown, however, any combination of filters whose area equals or exceeds the minimum area shown is satisfactory.

Accessories

Description	Used With	Kit Number	Catalog Number
Propane Conversion Kit	All 80 Single Stage Models	ALPKT572	1.831021
Upflow Side Return Filter Kit (16 x 25 filter)	All Upflow Capable Models	AFILT524	1.841018
Counterflow Filter Kit	All Counterflow Models	AFILT525	1.841019
Bottom Return Kit	All Upflow Capable Models	AFILT529	1.841020
Side Return Filter for Single Return with 5 Tons Airflow (double 16 x 20 filter)	All Upflow Capable Models	AFILTHA7	1.841005
Twinning Kit	All Single Stage Models	ATWIN579	1.841136
Combustible Floor Base for 14.5 inch Wide Units	All Counterflows for A width cabinets	ABASE511	1.841014
Combustible Floor Base for 17.5 inch Wide Units	All Counterflows for B width cabinets	ABASE512	1.841015
Combustible Floor Base for 21 inch Wide Units	All Counterflows for C width cabinets	ABASE568	1.841035
Combustible Floor Base for 24.5 inch Wide Units	All Counterflows for D width cabinets	ABASE569	1.841036

Blower Performance Data

Upflow / Horizontal, Upflow

Direction	Model	Motor Size (hp)	Blower Size	Temp Rise (°F)	Blower Speed	*CFM @ ext. Static Pressure - in. w.c. with Filter(s)							
						.20	.30	.40	.50	.60	.70	.80	.90
Upflow / Horizontal Upflow	G1N80BT/U050D12A	1/3	10 x 6	30 - 60	Hi	1,310	1,270	1,210	1,165	1,090	1,015	950	850
					Med/Hi	1,060	1,045	1,025	990	955	895	800	775
					Med	870	860	845	820	790	755	685	610
					Low	785	765	745	715	665	640	580	525
	G1N80BT/U075D12A	1/3	10 x 6	40 - 70	Hi	1,270	1,235	1,195	1,145	1,080	1,025	945	860
					Med/Hi	1,035	1,015	990	965	925	895	860	820
					Med	845	845	820	795	760	720	680	620
					Low	720	715	690	675	645	620	570	525
	G1N80BT/U075D16B	1/2	10 x 8	35 - 65	Hi	1,780	1,680	1,635	1,540	1,445	1,335	1,265	1,125
					Med/Hi	1,560	1,510	1,480	1,400	1,340	1,235	1,115	995
					Med	1,305	1,285	1,270	1,215	1,175	1,100	1,030	895
					Low	1,115	1,060	1,040	985	905	805	615	385
	G1N80BT/U100D14B	1/3	10 x 8	45 - 75	Hi	1,660	1,610	1,540	1,475	1,415	1,335	1,245	1,105
					Med/Hi	1,395	1,360	1,325	1,280	1,225	1,165	1,035	960
					Med	1,105	1,100	1,075	1,045	1,010	970	905	665
					Low	930	925	905	880	845	795	645	570
	G1N80BT/U100D20C	3/4	12 x 10	35 - 65	Hi	2,160	2,135	2,100	2,040	2,005	1,945	1,860	1,785
					Med/Hi	1,790	1,765	1,745	1,720	1,685	1,645	1,590	1,525
					Med	1,560	1,525	1,515	1,495	1,455	1,410	1,375	1,320
					Med/Low	1,285	1,260	1,245	1,210	1,185	1,150	1,100	1,070
					Low	1,005	970	925	890	850	810	740	685
	G1N80BT100D22C	.9	12 x 10	35 - 65	Hi	2,335	2,235	2,200	2,115	2,070	1,990	1,870	1,770
					Med/Hi	2,125	2,080	2,065	1,980	1,945	1,830	1,755	1,700
					Med	1,970	1,935	1,900	1,845	1,770	1,690	1,625	1,460
					Med/Low	1,695	1,660	1,620	1,600	1,535	1,475	1,400	1,305
					Low	1,450	1,425	1,385	1,355	1,300	1,265	1,130	1,070
	G1N80BT/U125D20C	3/4	12 x 10	50 - 80	Hi	2,095	2,080	2,035	1,970	1,925	1,820	1,735	1,650
					Med/Hi	1,780	1,755	1,735	1,710	1,645	1,565	1,530	1,465
Med					1,570	1,530	1,520	1,485	1,435	1,395	1,350	1,235	
Med/Low					1,310	1,285	1,255	1,225	1,190	1,155	1,095	1,020	
Low					1,015	975	950	905	830	775	720	655	
Upflow	G1N80BU150D20D	3/4	12 x 10	55 - 85	Hi	2,035	2,020	1,975	1,950	1,895	1,855	1,780	1,685
					Med/Hi	1,695	1,685	1,665	1,635	1,590	1,540	1,480	1,415
					Med	1,480	1,470	1,450	1,420	1,385	1,340	1,270	1,210
					Med/Low	1,255	1,230	1,205	1,180	1,150	1,095	1,065	1,005
					Low	985	950	920	890	830	785	735	680

* .50 in W.C. max approved external static pressure

Blower Performance Data

Counterflow / Horizontal

Direction	Model	Motor Size (hp)	Blower Size	Temp Rise (°F)	Blower Speed	*CFM @ ext. Static Pressure - in. w.c. with Filter(s)							
						.20	.30	.40	.50	.60	.70	.80	.90
Counterflow / Horizontal	G1N80BR050D12A	1/3	10 x 6	35 - 65	Hi	1,330	1,290	1,235	1,170	1,135	1,035	935	865
					Med/Hi	1,100	1,085	1,055	1,020	970	915	830	755
					Med	890	875	860	830	805	755	695	645
					Low	760	740	730	715	685	645	605	530
	G1N80BR075D12A	1/3	10 x 6	40 - 70	Hi	1,295	1,250	1,200	1,135	1,075	1,020	935	860
					Med/Hi	1,045	1,035	1,010	975	935	880	815	750
					Med	850	845	830	815	780	745	690	625
					Low	730	720	705	685	660	620	580	500
	G1N80BR075D16B	1/2	10 x 8	40 - 70	Hi	1,855	1,780	1,680	1,635	1,540	1,445	1,335	1,265
					Med/Hi	1,585	1,560	1,510	1,480	1,400	1,340	1,235	1,115
					Med	1,340	1,305	1,295	1,270	1,215	1,175	1,100	1,030
					Low	1,135	1,115	1,060	1,040	985	905	805	615
	G1N80BR100D14B	1/3	10 x 8	45 - 75	Hi	1,725	1,660	1,605	1,500	1,430	1,345	1,210	1,115
					Med/Hi	1,440	1,430	1,405	1,345	1,260	1,190	1,095	995
					Med	1,160	1,145	1,135	1,100	1,065	1,010	950	845
					Low	985	980	975	950	905	845	790	695
	G1N80BR100D20C	3/4	12 x 10	45 - 75	Hi	2,165	2,140	2,090	2,055	2,000	1,925	1,905	1,815
					Med/Hi	1,785	1,755	1,725	1,700	1,670	1,600	1,525	1,410
					Med	1,580	1,545	1,535	1,515	1,460	1,405	1,315	1,135
					Med/Low	1,325	1,305	1,275	1,230	1,195	1,135	1,025	970
					Low	1,015	995	955	905	845	785	690	650
	G1N80BR125D20C	3/4	12 x 10	45 - 75	Hi	2,175	2,150	2,095	2,020	1,955	1,875	1,770	1,640
					Med/Low	1,830	1,815	1,775	1,740	1,685	1,630	1,545	1,390
					Med	1,620	1,600	1,565	1,525	1,495	1,400	1,320	1,115
					Med/Low	1,340	1,315	1,290	1,255	1,210	1,140	1,020	965
					Low	1,030	995	960	910	870	800	745	650
	G1N80BR150D20C	3/4	12 x 10	55 - 85	Hi	2,090	2,080	2,060	2,020	1,975	1,915	1,835	1,760
					Med/Hi	1,770	1,755	1,730	1,705	1,660	1,620	1,555	1,485
Med					1,550	1,540	1,520	1,495	1,460	1,415	1,365	1,290	
Med/Low					1,325	1,305	1,285	1,245	1,215	1,160	1,040	980	
Low					1,040	1,000	970	905	855	810	755	680	

* .50 in W.C. max approved external static pressure

G1N80BT = Upflow / Horizontal

Dimensions (in.)

Model	A	B	C	D
G1N80BT050D12A	14-1/2	13-1/2	13-1/4	4-7/8
G1N80BT075D12A				
G1N80BT075D16B	17-1/2	16-1/2	16-1/4	6-1/2
G1N80BT100D14B				
G1N80BT100D20C	21	20	19-3/4	8-1/4
G1N80BT125D22C				
G1N80BT125D20C				

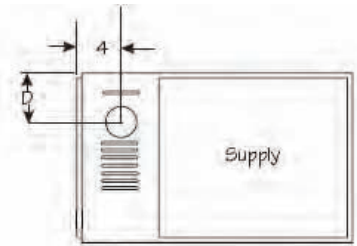

*Clearances (in.) Upflow

Model	Top	Sides	Front	Back	Vent
G1N80BT050D12A	1	1 ¹	4 ³	0	6 ²
G1N80BT075D12A					
G1N80BT075D16B	1	0	4 ³	0	6 ²
G1N80BT100D14B					
G1N80BT100D20C	1	0	4 ³	0	6 ²
G1N80BT100D22C					
G1N80BT125D20C					

¹0" IF B1 Vent is used
²1" IF B1 Vent is used
³2" IF B1 Vent is used

May be installed on combustible flooring

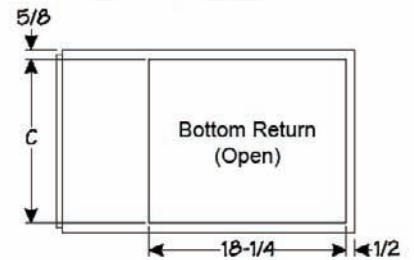
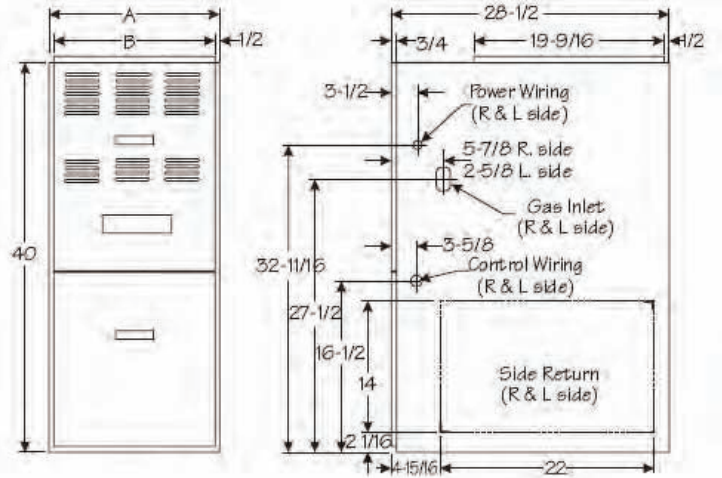

*Clearances (in.) Horizontal

Model	Right Side	Left Side	Back	Vent	Airflow			
					Left to Right		Right to Left	
					Top	Bottom	Top	Bottom
G1N80BT050D12A	1	1	0	18	1	0	1	0
G1N80BT075D12A								
G1N80BT075D16B	1	1	0	18	1	0	1	0
G1N80BT100D14B								
G1N80BT100D20C	1	1	0	18	1	0	1	0
G1N80BT100D22C								
G1N80BT125D20C								

May be installed on combustible flooring

*Clearances to combustibles. Service access to the front of the furnace to remove the blower assembly is 18"

G1N80BU = Upflow

Dimensions (in.)

Model	A	B	C	D
G1N80BU050D12A	14-1/2	13-1/2	11	4-7/8
G1N80BU075D12A				
G1N80BU075D16B	17-1/2	16-1/2	14	6-1/2
G1N80BU100D14B				
G1N80BU100D20C	21	20	17-1/2	8-1/4
G1N80BU125D20C				
G1N80BU150D20D	24-1/2	23-1/2	21	10

*Clearances (in.) Upflow

Model	Top	Right Side	Front	Back	Vent
G1N80BU050D12A	1	1 ¹	4 ³	0	6 ²
G1N80BU075D12A					
G1N80BU075D16B	1	0	4 ³	0	6 ²
G1N80BU100D14B					
G1N80BU100D20C	1	0	4 ³	0	6 ²
G1N80BU125D20C					
G1N80BU150D20D	1	0	4 ³	0	6 ²

¹0" IF B1 Vent is used
²1" IF B1 Vent is used
³2" IF B1 Vent is used

May be installed on combustible flooring

*Clearances to combustibles. Service access to the front of the furnace to remove the blower assembly is 18"

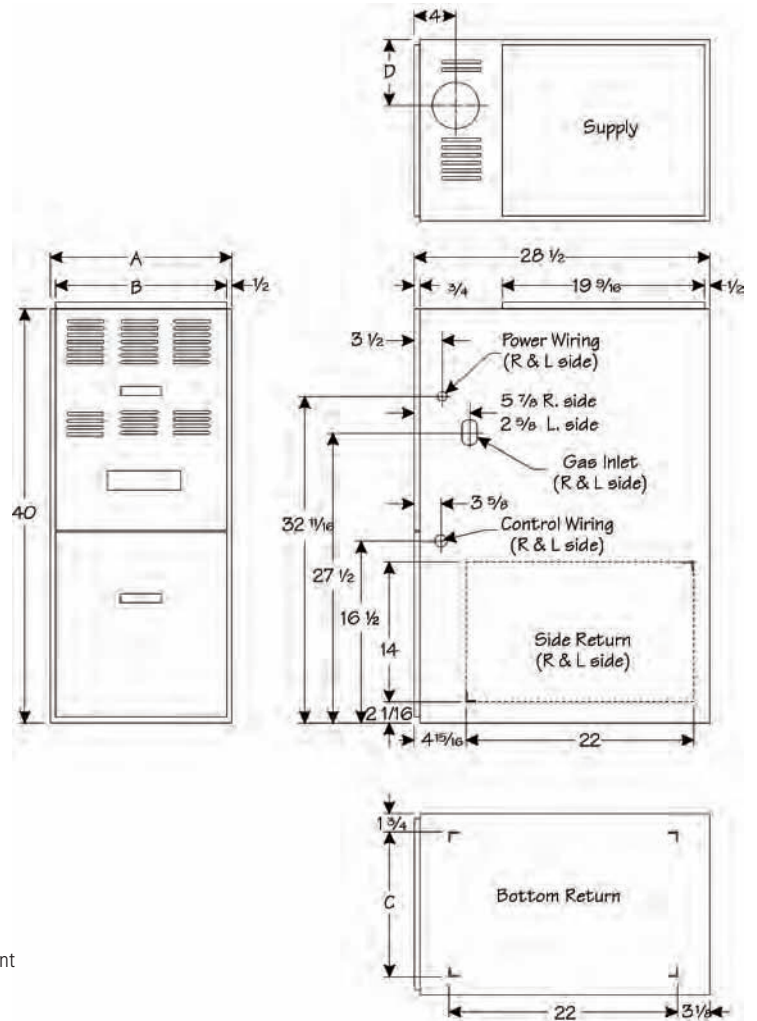

G1N80

G1N80BR = Counterflow / Horizontal

Dimensions (in.)

Model	A	B	C	D
G1N80BR050D12A	14-1/2	13-1/2	13-1/4	4-7/8
G1N80BR075D12A				
G1N80BR075D16B	17-1/2	16-1/2	16-1/4	6-1/2
G1N80BR100D14B				
G1N80BR100D20C	21	20	19-3/4	8-1/4
G1N80BR125D22C				
G1N80BR150D20D	24-1/2	23-1/2	23-1/4	10

***Clearances (in.) Counterflow**

Model	Top	Sides	Front	Back	Vent
G1N80BR050D12A	1	1 ¹	4 ³	0	6 ²
G1N80BR075D12A					
G1N80BR075D16B	1	0	4 ³	0	6 ²
G1N80BR100D14B					
G1N80BR100D20C	1	0	4 ³	0	6 ²
G1N80BR125D22C					
G1N80BR150D20D	1	0	4 ³	0	6 ²

¹0" IF B1 Vent is used
²1" IF B1 Vent is used
³2" IF B1 Vent is used

Note: For installation on combustible flooring only when installed on special combustible floor base.

***Clearances (in.) Horizontal**

Model	Right Side	Left Side	Front	Back	Vent	Airflow			
						Left to Right		Right to Left	
						Top	Bottom	Top	Bottom
G1N80BR050D12A	1	1	18	0	6 ²	1	0	1	0
G1N80BR075D12A									
G1N80BR075D16B	1	1	18	0	6 ²	1	0	1	0
G1N80BR100D14B									
G1N80BR100D20C	1	1	18	0	6 ²	1	0	1	0
G1N80BR100D22C									
G1N80BR125D20C	1	1	18	0	6 ²	1	0	1	0

¹0" IF B1 Vent is used
²1" IF B1 Vent is used
³2" IF B1 Vent is used

*Clearances to combustibles. Service access to the front of the furnace to remove the blower assembly is 18"

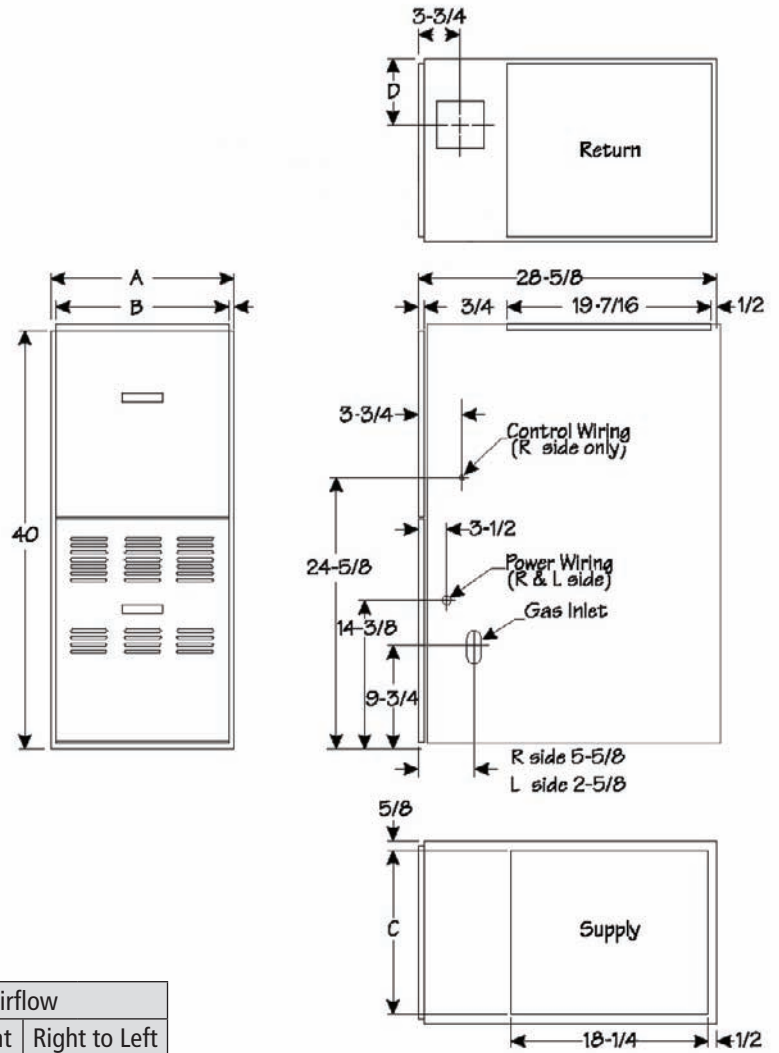

Built for life. Yours.

All specifications and illustrations subject to change without notice and without incurring obligations.

www.airease.com
 1-800-448-5872